

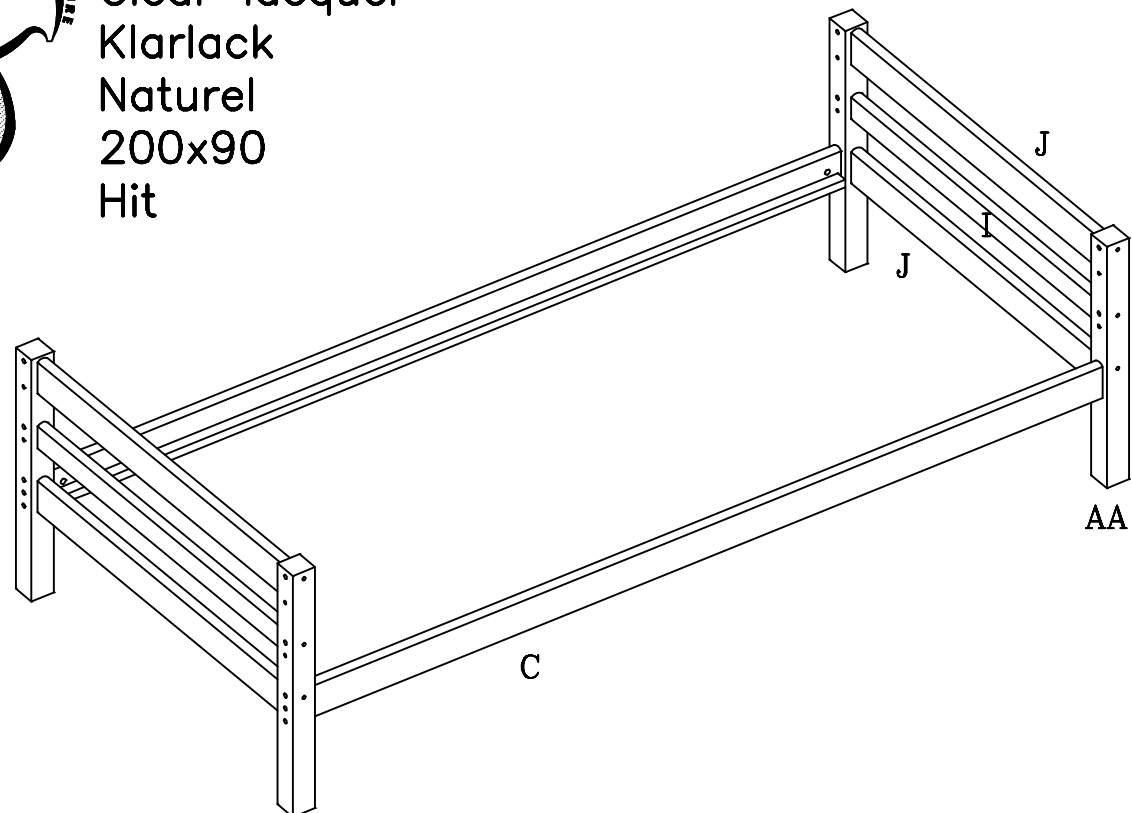

80-06101-1
 Clear lacquer
 Klarlack
 Naturel
 200x90
 Hit



Before assembling this product, please ensure that all the components supplied comply with the list on this page. All Screw-type fittings can be tightened with this tool.

Avant de commencer l'assemblage, veuillez contrôler si tous les objets indiqués sont présents. Tous les vis peuvent être serrés par cet outil.

Bevor Sie mit dem Aufbau beginnen, kontrollieren Sie ob alle auf der Zeichnung angegebenen Teile vorhanden sind. Bitte verwenden Sie zur Montage einen Kreuzschraubzieher und den beiliegenden Innensechskantschlüssel.

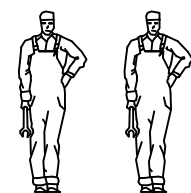
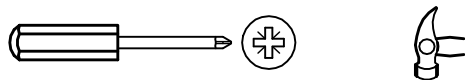

Ware-nr.
Part no.
Réf No

Stck.
Qty.
Qté.

Siehe Bild-nr.
See picture no.
Image no

Mass
Dim.
Dim.

12-05506012-1
4 stck/pcs.

1305-19671-1
2 stck/pcs.

12-02608732-1
2 stck/pcs.

12-02608731-1
4 stck/pcs.

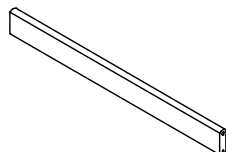
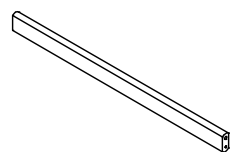
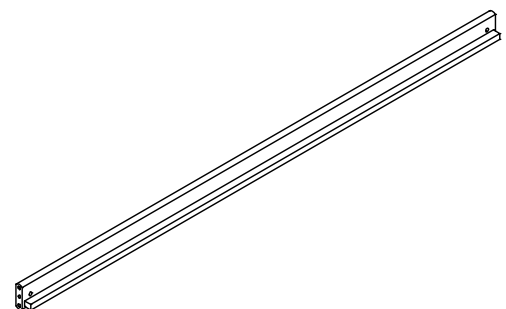
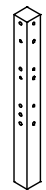

AA 601x55x55

C 1967x89x26

I 873x65x26

J 873x89x26

3913-08100 4 stck/pcs.

3909-70100 12 stck/pcs.

3930-10050 20 stck/pcs.

3901-40030 30 stck/pcs.

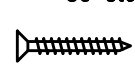
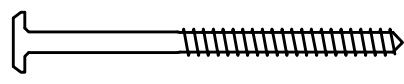
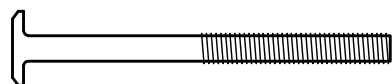

Z1 M8x100 mm.

Z2 ø7x100 mm.

Z4 ø10x50 mm.

Z6 ø4x30 mm.

3922-08018 4 stck/pcs.

3938-000081-1 16 stck/pcs.

3938-00010-1 24 stck/pcs.

4033-005 1 stck/pcs.

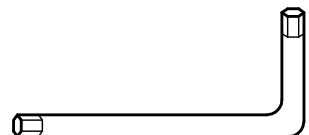

Z8 M8x12x18 mm.

Z10 ø8 mm.

Z11 ø10 mm.

Z13 5 mm.

CLEANING:
LACQUERED:

Wooden, lacquered and painted as well as laminated surfaces should be wiped over with a cloth and a mild soap.

OIL:

Oiled surfaces can be cleaned with soapy water, e.g. brown soap. Wipe with a clean cloth.

To maintain the natural life in the furniture which is provided by the oil treatment, we recommend an oil aftercare of the furniture 1-2 times a year. The colourless natural oil for maintenance of oil-treated furniture is available at your local furniture store.

Important:

Please keep these instructions in a safe place for future use. (Repare, maintenance, second hand sale etc).

Packed in a re-cycling cardboard box.

In the unlikely event that this product has missing or damaged parts, please call: 0113 234 9444 or fax:0045 9772 3233 or e-mail: service@thuka.dk to obtain spares.

Nettoyage:

LAQUÉ:

Les surfaces bois, laqués, peintes et laminés peuvent être séchées avec un chiffon et un savon doux.

HUILE:

Des surfaces huilés peuvent être nettoyées avec l'eau savonneuse, par ex. savon mou, et essuyées vec un chiffon pur.

Pour maintenir la vie naturelle dans la meuble, que l'huile donne, nous recommandons un traitement complémentaire d'huile 1-2 fois par an. L'huile naturelle sans couleurs pour maintenance des meubles est peut être achetée à votre magasin d'ameublement local.

Important:

Veillez garder ces instructions pour l'usage future. (Réparations, maintenance, revente ect).

Emballé dans une boîte de carton réusable.

Au cas improbable des manques ou des marchandises gâtées veuillez téléphoner: 0113 234 9444 ou fax:0045 9772 3233 ou e-mail: service@thuka.dk pour obtenir des remplacements.

Reinigung:

Lackierte Möbel:

Lackierte Holzoberflächen können mit einem sauberen Lappen und mildes Seifenwasser gereinigt werden.

Geölte Möbel:

Geölte Holzoberflächen können mit einem sauberen Lappen und Seifenwasser, z.B. Schmierseife, gereinigt werden. Um das natürliche Aussehen des Holzes zu behalten, ist eine Öl-Nachbehandlung vom Möbelstück 1 bis 2 Mal pro Jahr empfehlenswert. Das farblose Öl, für die Nachbehandlung der Möbel, kann in Ihrem Möbelgeschäft gekauft werden.

Wichtig:

O.g. Erhaltungsanleitung bitte für die Zukunft bewaren.

Das Möbel wird in umweltfreundlicher Recyclingpappe-Verpackung geliefert.

Sollte das Produkt, wider Erwartung, mangelhaft oder beschädigt sein, setzen Sie sich bitte in Verbindung mit uns für Ersatzteile, auf Fax Nr: 0045 9772 3233 oder Email: service@thuka.dk.

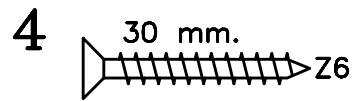
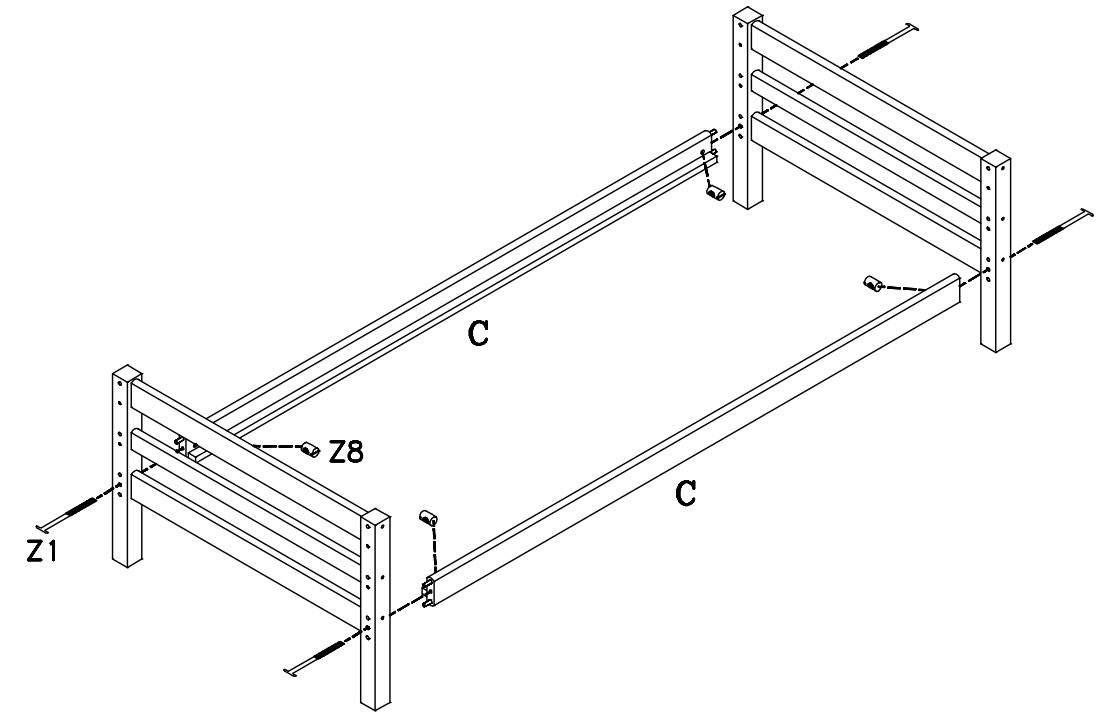
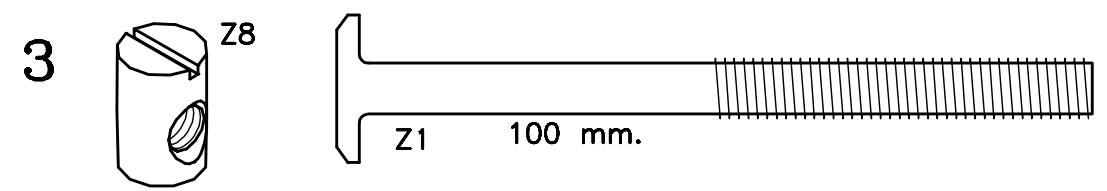
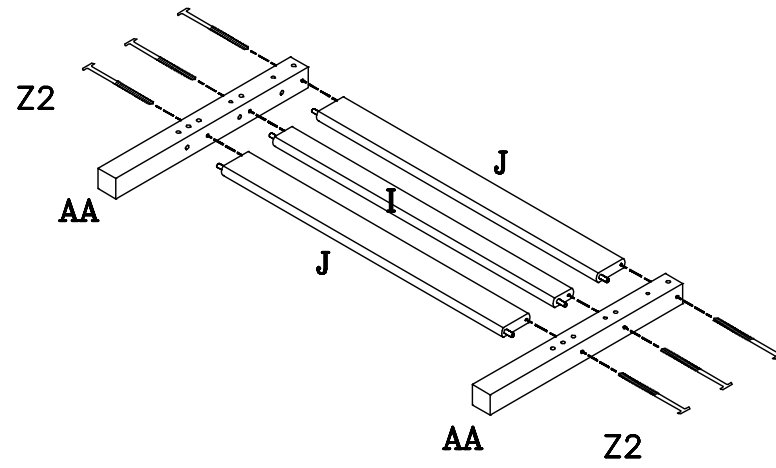
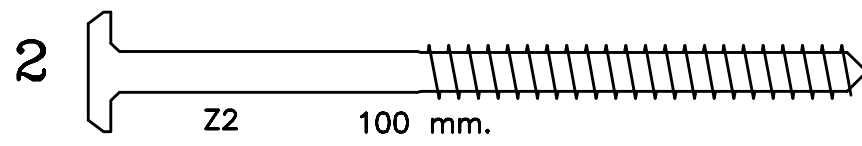
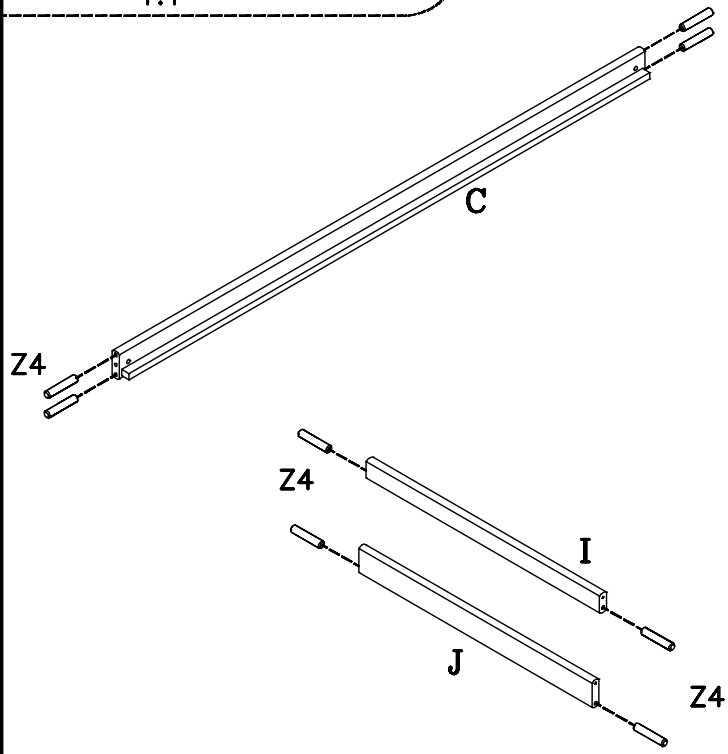
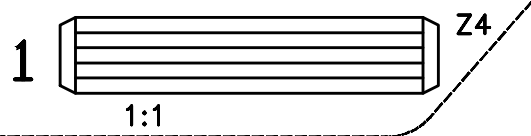

Push
Drücken
Appuyer

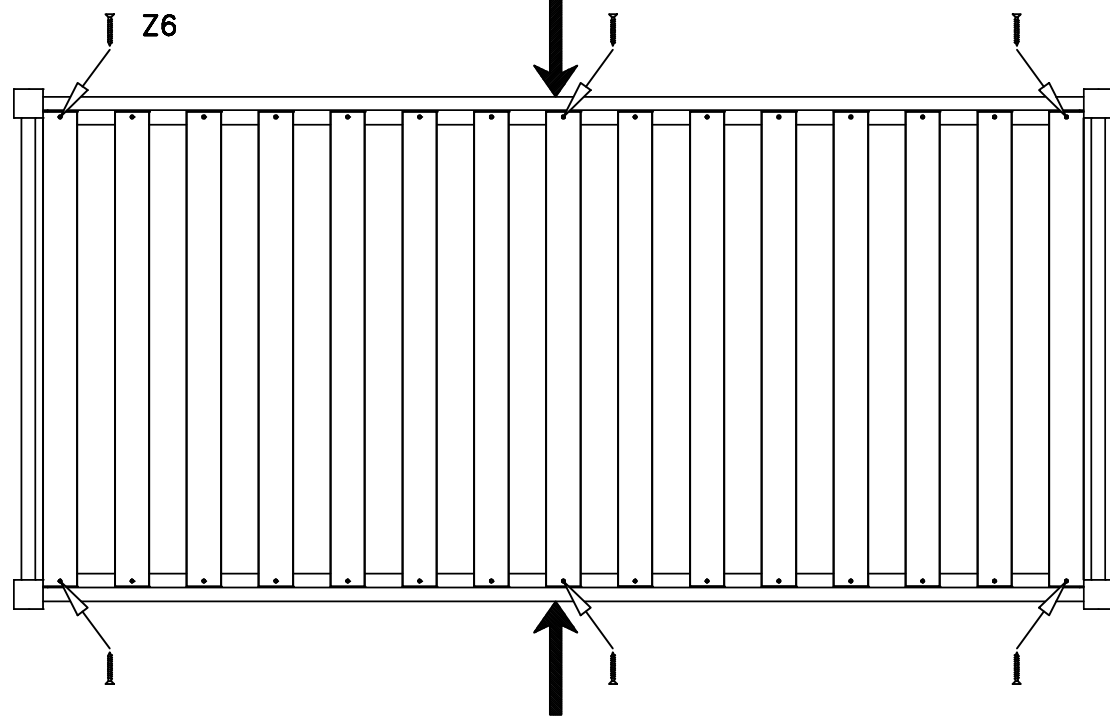

Push
Drücken
Appuyer

