

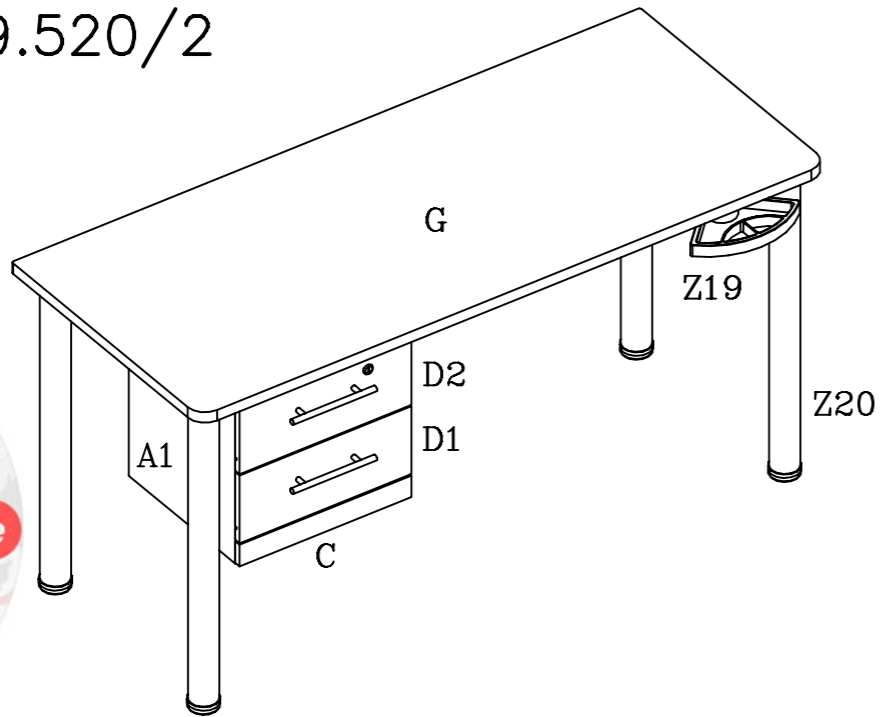

129.520/2



B 99187 1 stck./pcs. 	B 99188 3 stck./pcs. 	B 6007011 4 stck./pcs. 
Z21 90x90 B 98475 1 stck./pcs. 	Z22 194x95.5 B 98990 1 stck./pcs. 	Z20 ø60x701 
Z18 ø19x29 	Z19 28x180x250 	Z20 ø60x701 1 stck./pcs. 

Before assembling this product, please ensure that all the components supplied comply with the list on this page. All Screw-type fittings can be tightened with this tool.

Avant de commencer l'assemblage, veuillez contrôler si tous les objets indiqués sont présents. Tous les vis peuvent être serrés par cet outil.

Bevor Sie mit dem Aufbau beginnen, kontrollieren Sie ob alle auf der Zeichnung angegebenen Teile vorhanden sind. Bitte verwenden Sie zur Montage einen Kreuzschraubenzieher und den beiliegenden Innensechskantschlüssel.

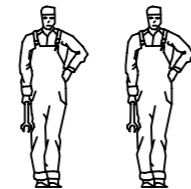
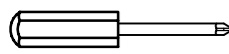

Ware-nr.  
Part no.  
Réf No  
  
Siehe Bild-nr.  
See picture no.  
Image no  
  
Stck.  
Qty.  
Qté.  
  
Mass  
Dim.  
Dim.

E 311524200

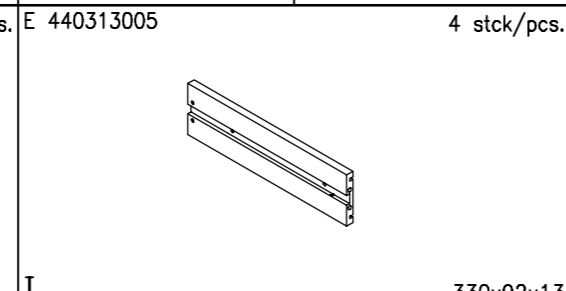
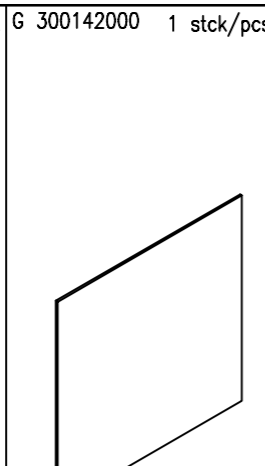
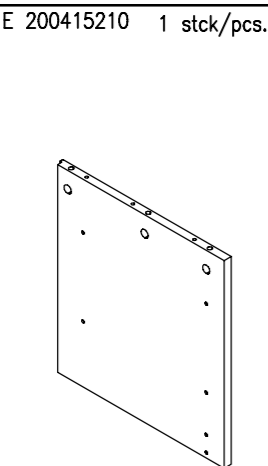
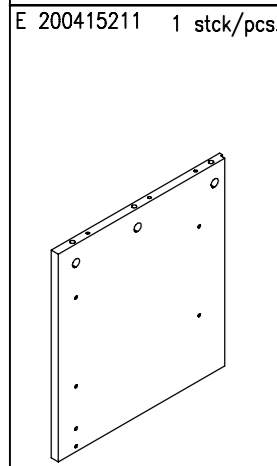
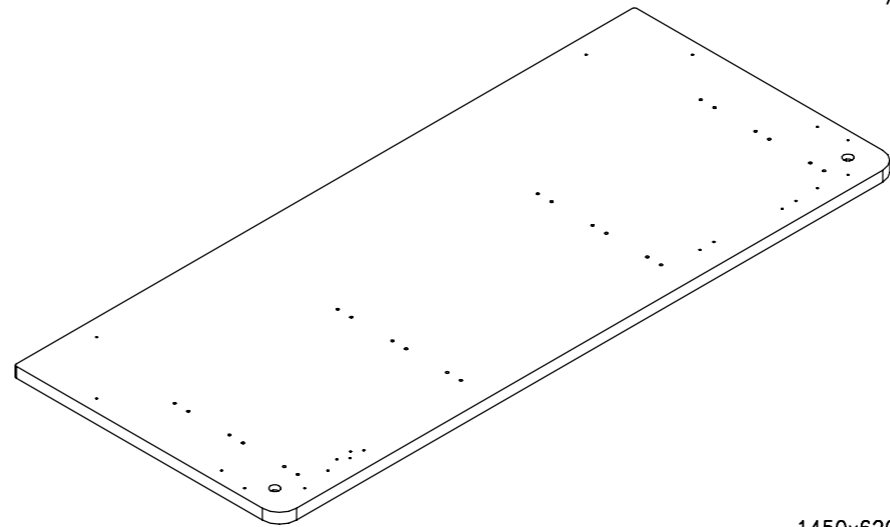

A1 374x350x15

A2 374x350x15

B 370x383x3

I 330x92x13

G 1450x620x24

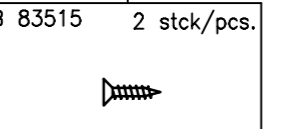
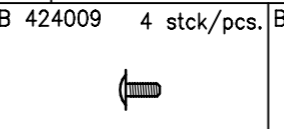
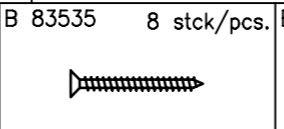
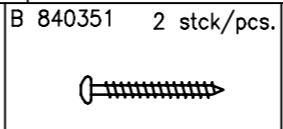
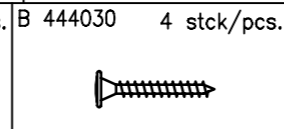
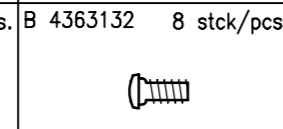
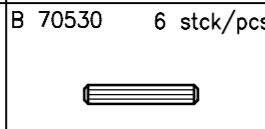
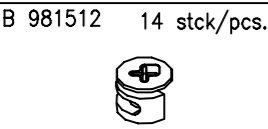
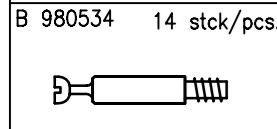

Z1 ø5x34 mm.

Z2 ø15x9.5 mm.

Z3 ø5x30 mm.

Z4 ø6.3x13 mm.

Z5 ø4x30 mm.

Z6 ø4x35 mm.

Z7 ø3.5x35 mm.

Z8 M4x9 mm.

Z9 ø3.5x15 mm.

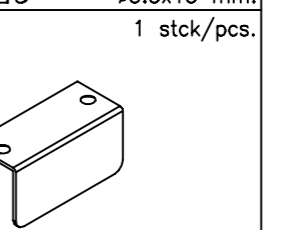
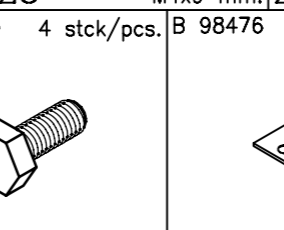
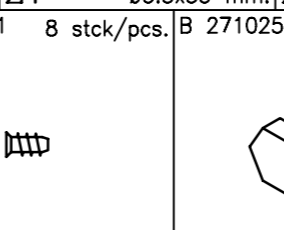
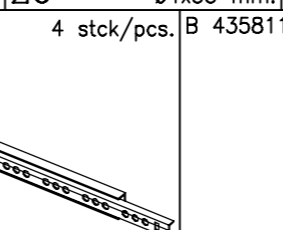
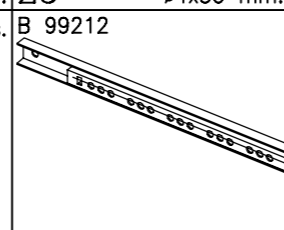
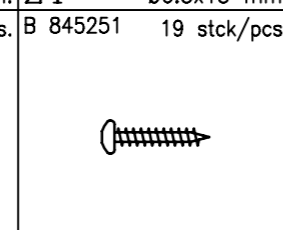
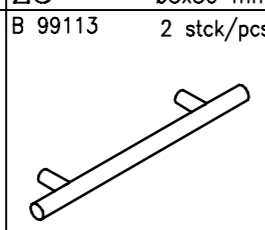
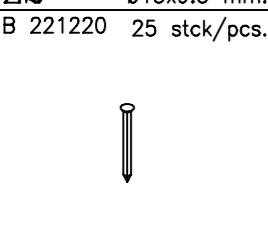
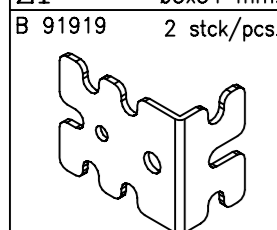

Z10 50x27x41 mm.

Z11 1.2x20 mm.

Z12 128 mm.

Z13 ø4.5x25 mm.

Z14 310x17x10 mm.

Z15 ø5.8x11 mm.

Z16 M10x25 mm.

Z17 20x17x40 mm.

Z17 20x17x40 mm.

**CLEANING:**

**LACQUERED:**

Wooden, lacquered and painted as well as laminated surfaces should be wiped over with a cloth and a mild soap.

**OIL:**

Oiled surfaces can be cleaned with soapy water, e.g. brown soap. Wipe with a clean cloth.

To maintain the natural life in the furniture which is provided by the oil treatment, we recommend an oil aftercare of the furniture 1-2 times a year. The colourless natural oil for maintenance of oil-treated furniture is available at your local furniture store.

**Important:**

Please keep these instructions in a safe place for future use. (Repaire, maintenance, second hand sale etc).

Packed in a re-cycling cardboard box.

In the unlikely event that this product has missing or damaged parts, please call: 0113 234 9444 or fax:0045 9772 3233 or e-mail: service@thuka.dk to obtain spares.

**Nettoyage:**

**LAQUÉ:**

Les surfaces bois, laqués, peintes et laminés peuvent être sechées avec un chiffon et un savon doux.

**HUILE:**

Des surfaces huilés peuvent être nettoyées avec l'eau savonneuse, par ex. savon mou, et essuyées vec un chiffon pur.

Pour maintenir la vie naturelle dans la meuble, que l'huile donne, nous recommandons un traitement complémentaire d'huile 1-2 fois par an.

L'huile naturelle sans couleurs pour maintenance des meubles est peut être achetée à votre magasin d'ameublement local.

**Important:**

Veillez garder ces instructions pour l'usage future. (Réparations, maintenance, revente ect).

Emballé dans une boîte de carton réusable.

Au cas improbable des manques ou des marchandises gâtées veuillez téléphoner: 0113 234 9444 ou fax:0045 9772 3233 ou e-mail: service@thuka.dk pour obtenir des remplacements.

**Reinigung:**

**Lackierte Möbel:**

Lackierte Holzoberflächen können mit einem sauberen Lappen und mildes Seifenwasser gereinigt werden.

**Geölte Möbel:**

Geölte Holzoberflächen können mit einem sauberen Lappen und Seifenwasser, z.B. Schmierseife, gereinigt werden. Um das natürliche Aussehen des Holzes zu behalten, ist eine Öl-Nachbehandlung vom Möbelstück 1 bis 2 Mal pro Jahr empfehlenswert. Das farblose Öl, für die Nachbehandlung der Möbel, kann in Ihrem Möbelgeschäft gekauft werden.

**Wichtig:**

O.g. Erhaltungsanleitung bitte für die Zukunft bewaren.

Das Möbel wird in umweltfreundlicher Recyclingpappe-Verpackung geliefert.

Sollte das Produkt, wider Erwartung, mangelhaft oder beschädigt sein, setzen Sie sich bitte in Verbindung mit uns für Ersatzteile, auf Fax Nr: 0045 9772 3233 oder Email: service@thuka.dk.

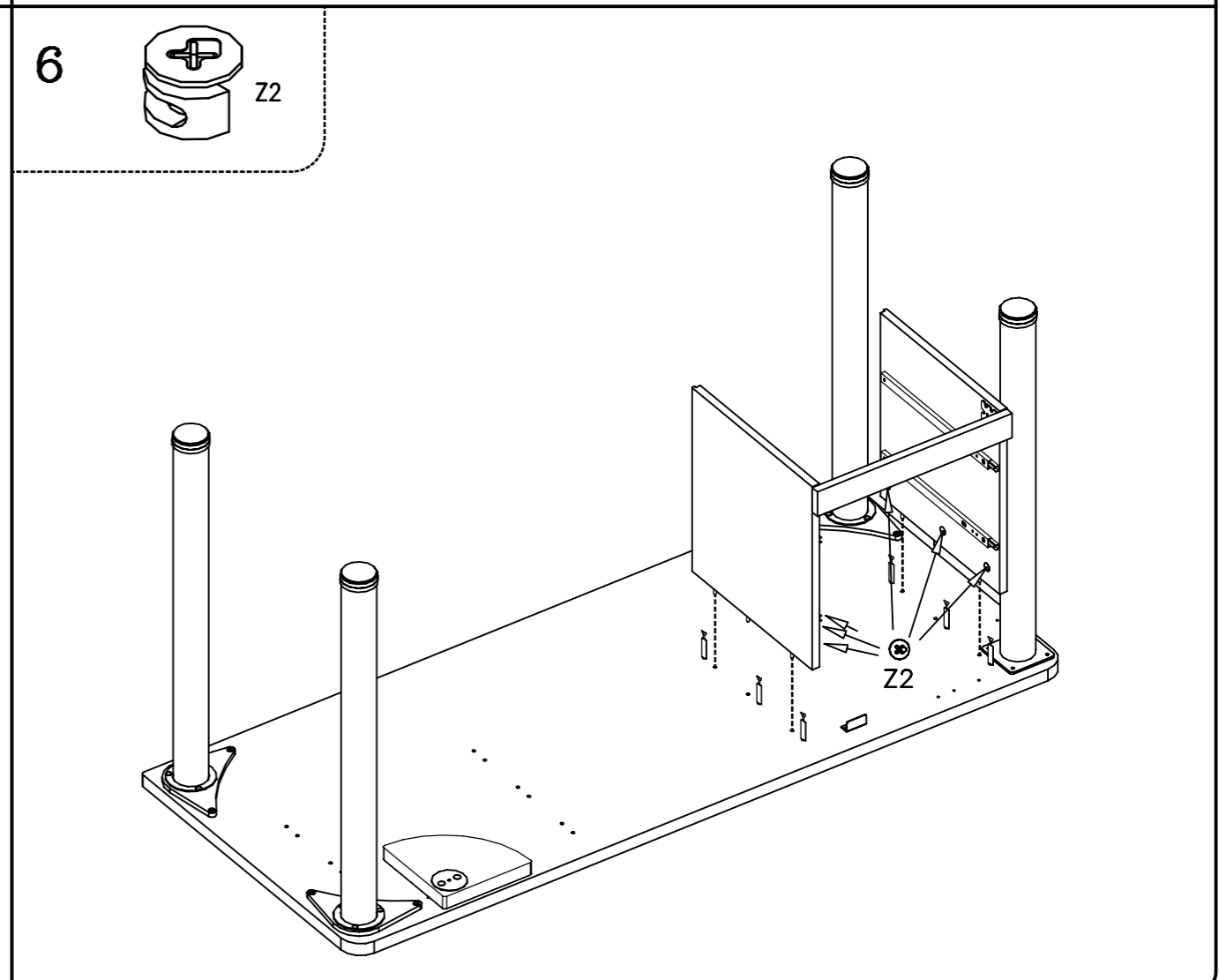
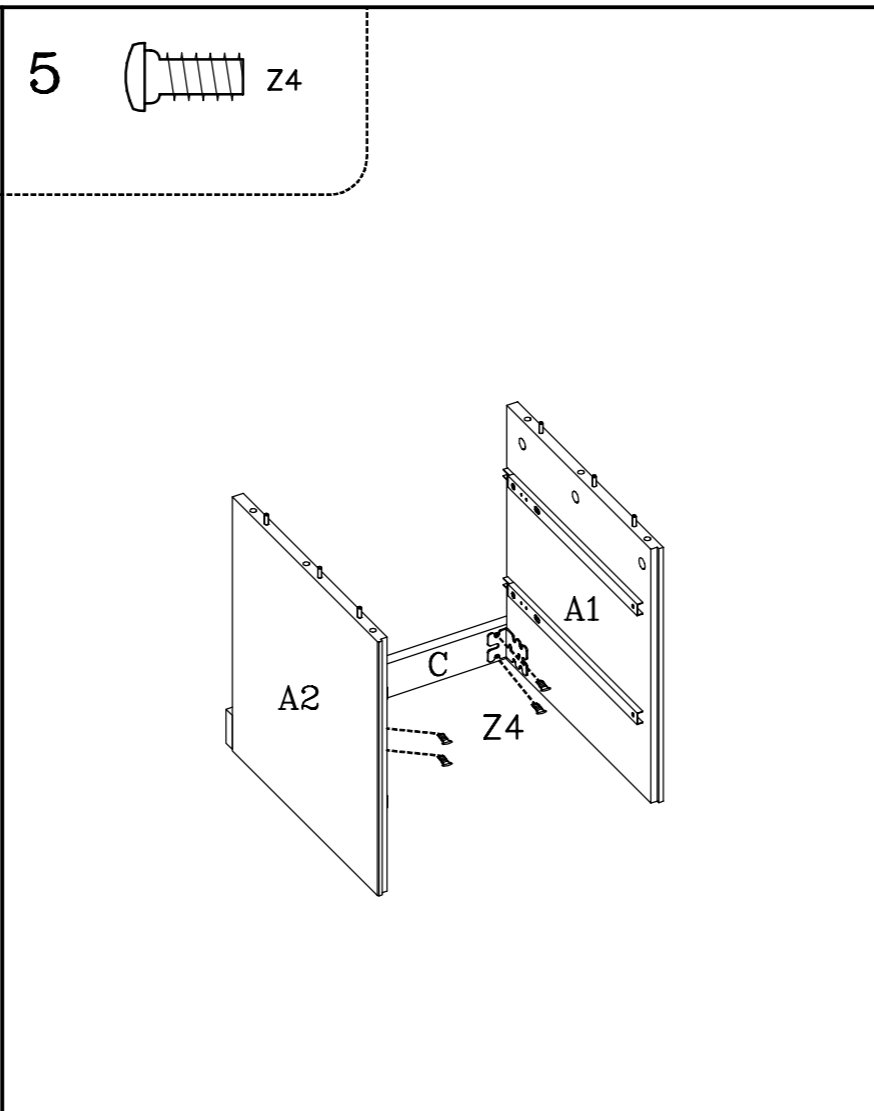
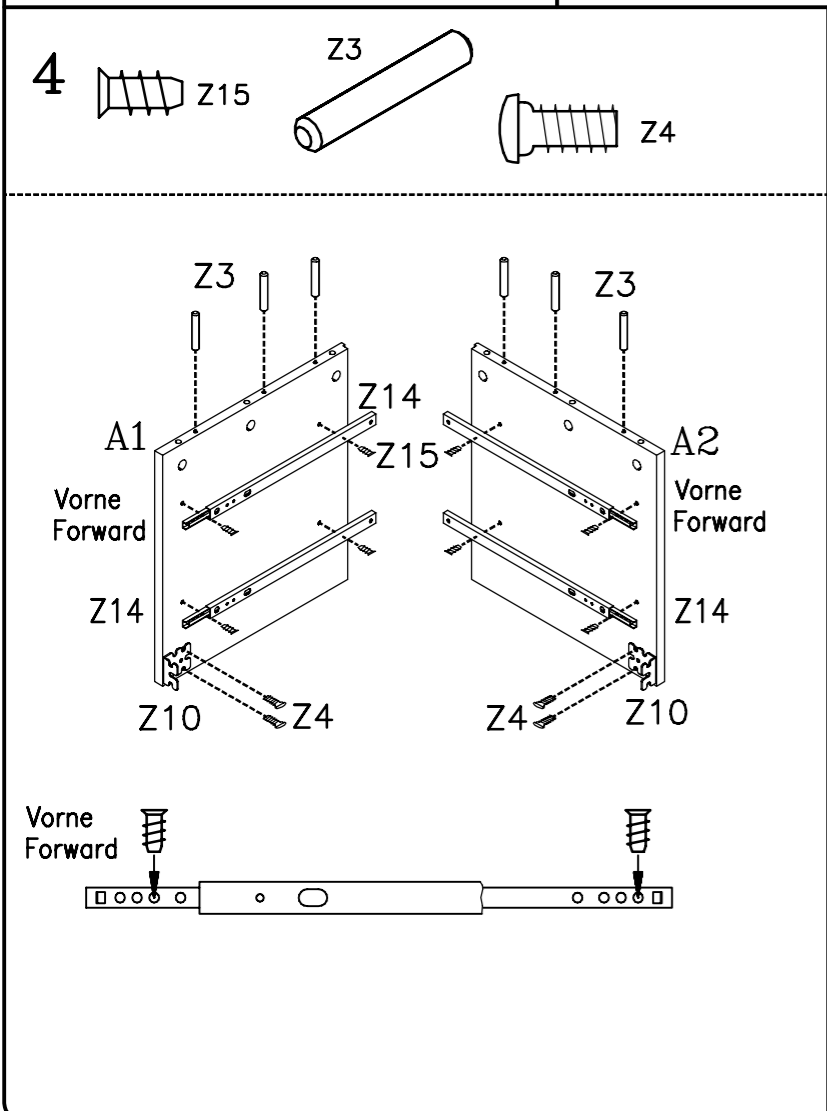
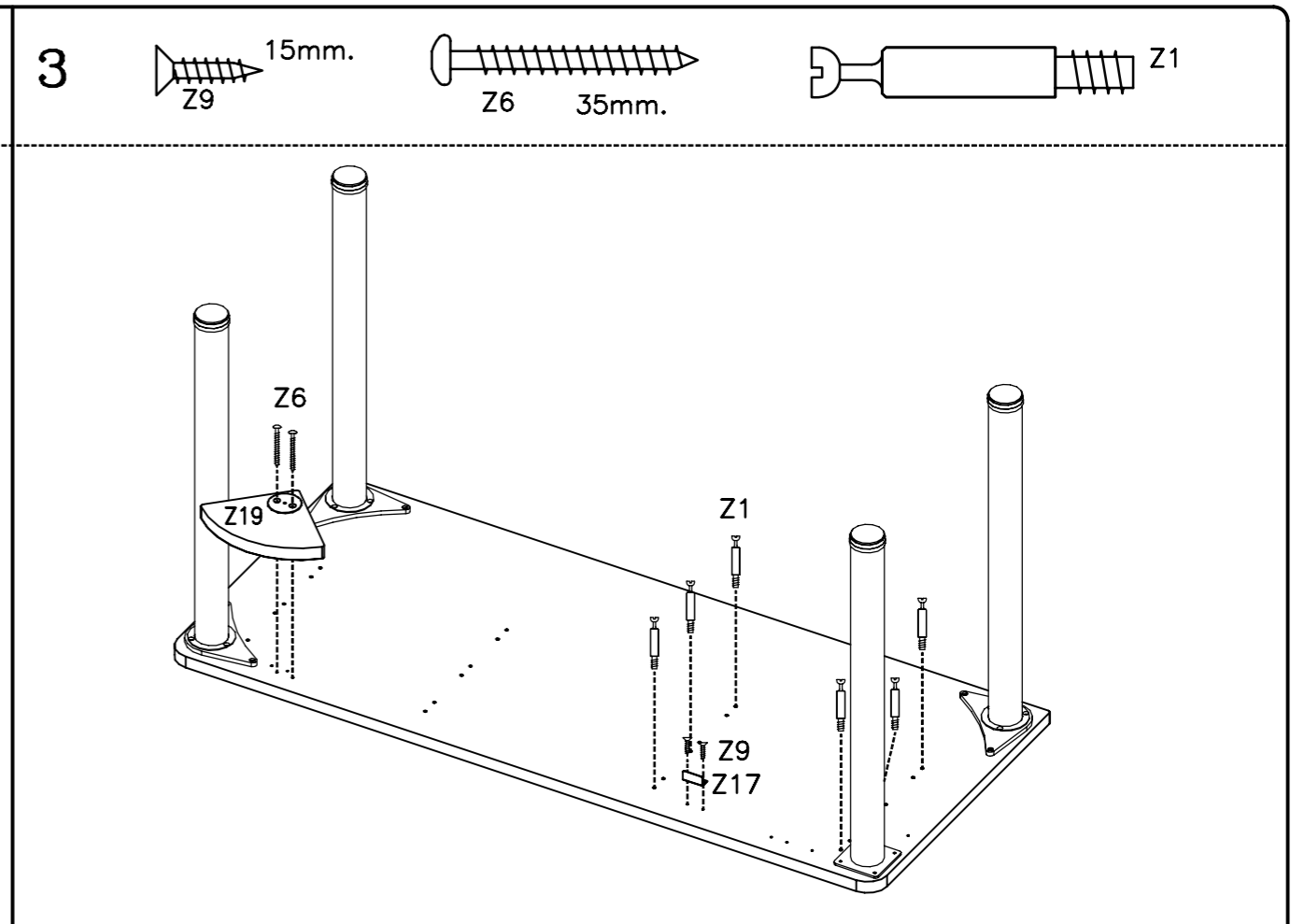
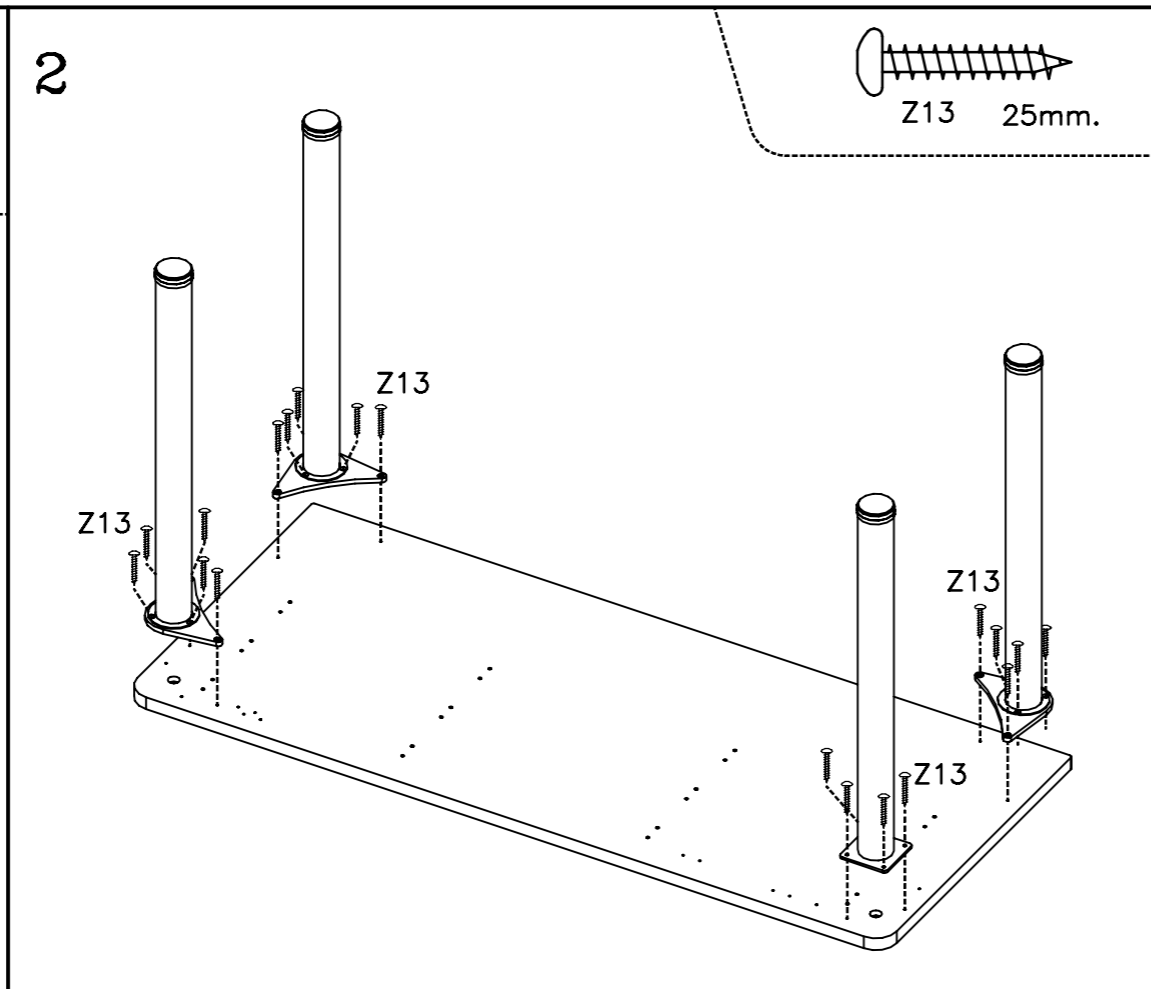
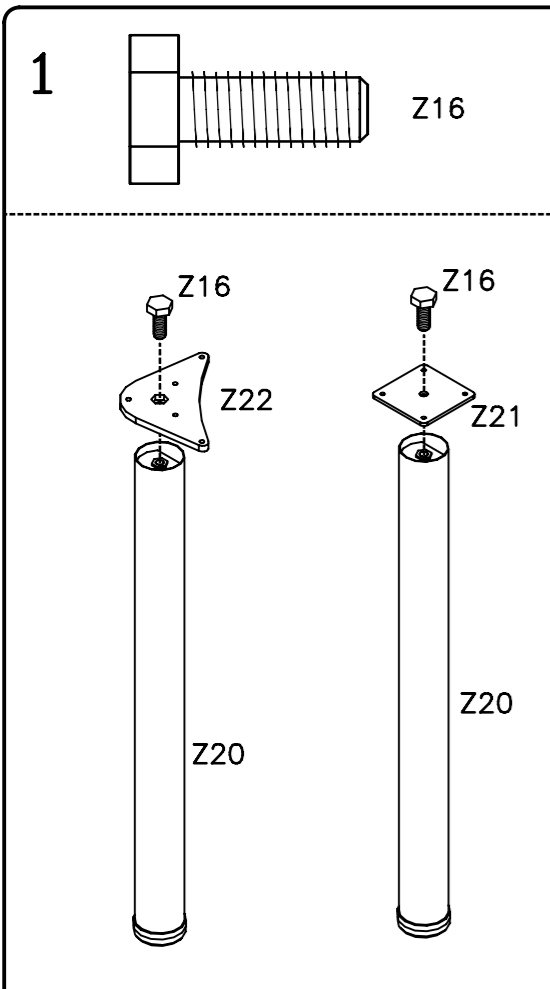

7

Z11

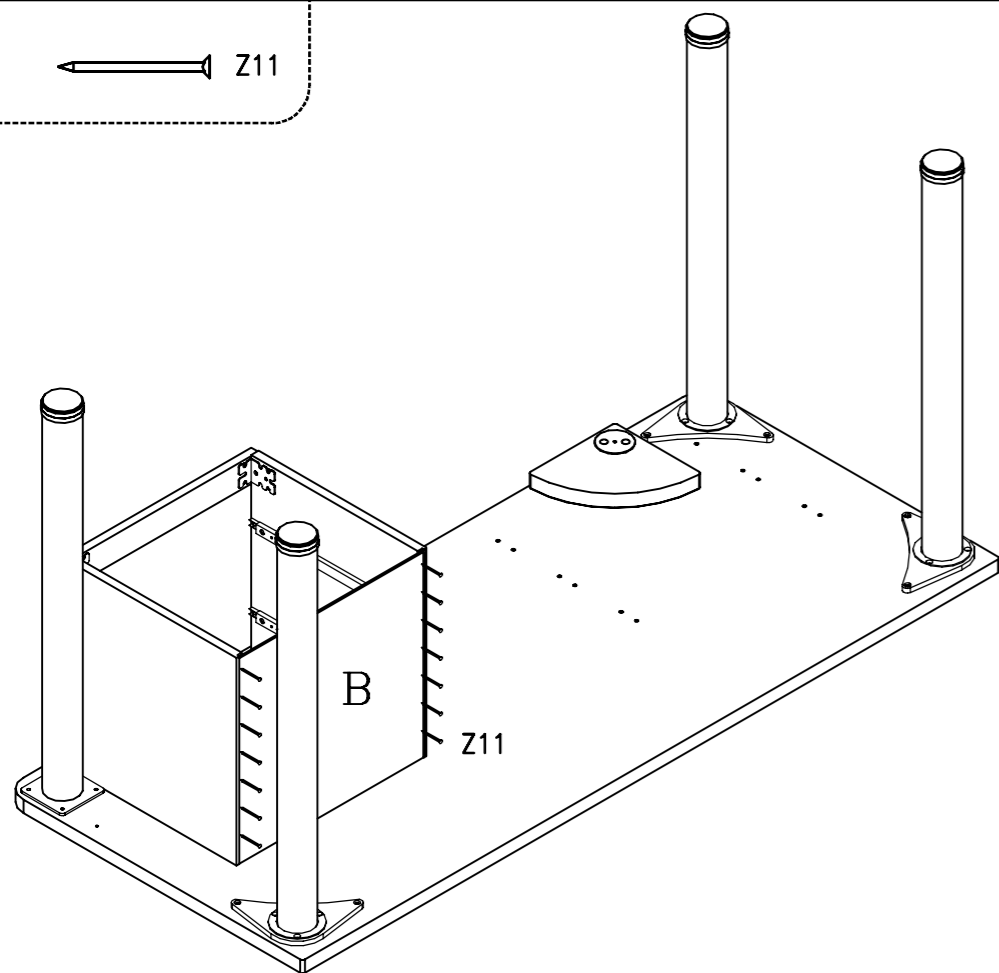

8

Z18

D1

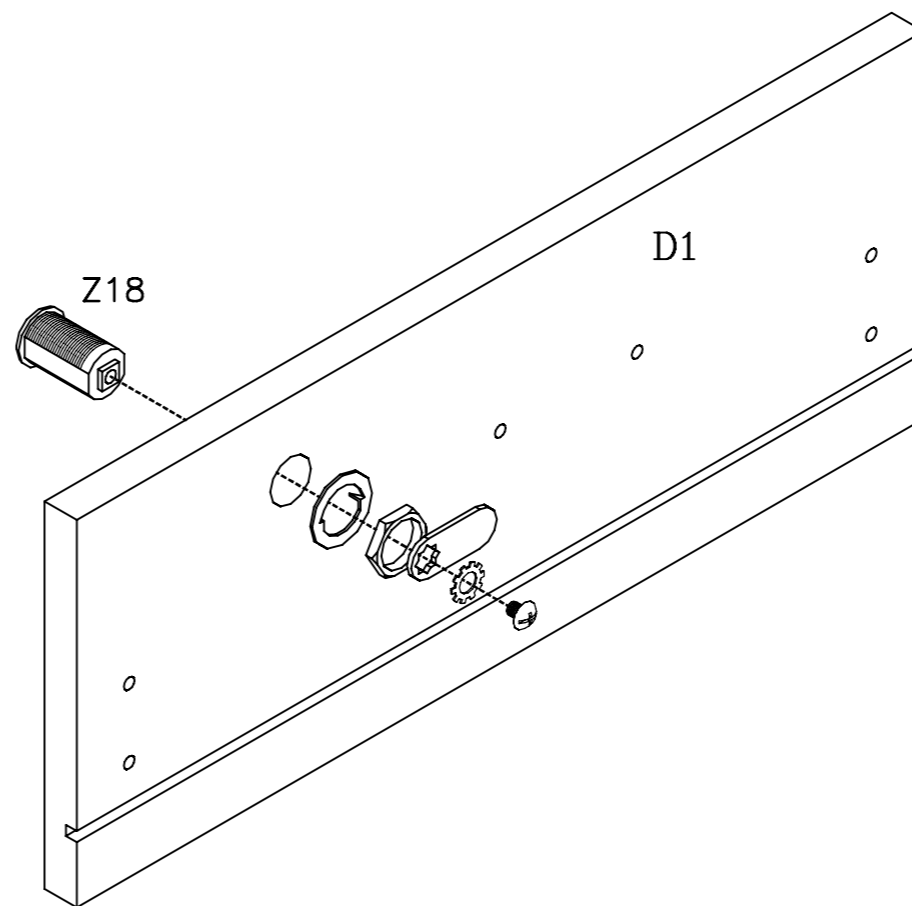

9

30 mm.

Z5

Z1

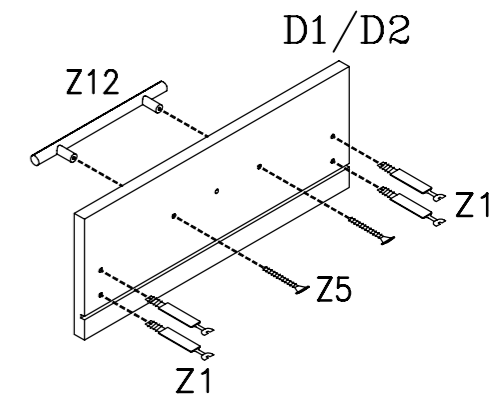

10

Z2

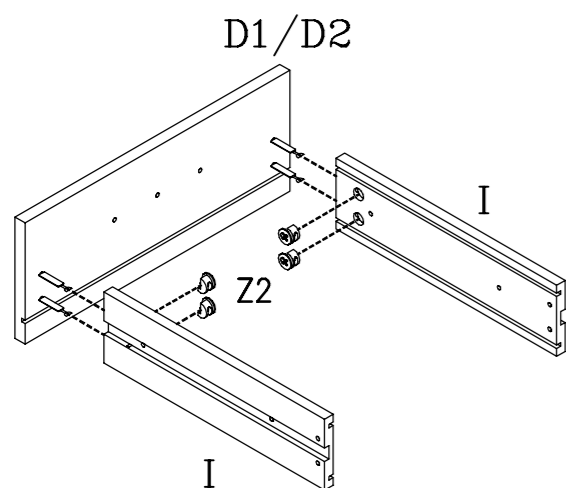

11

35 mm.

Z7

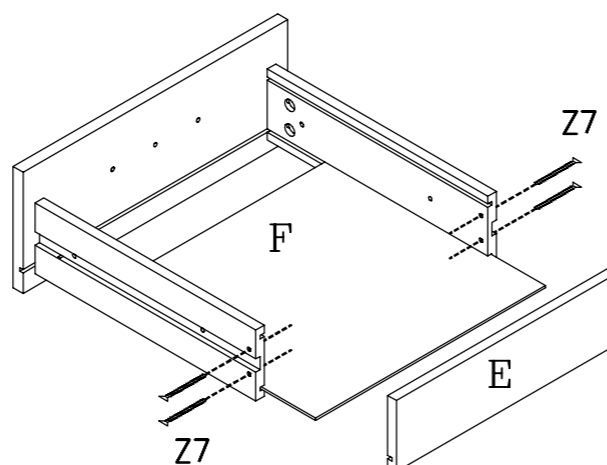

12

Z8

