

FLEXA®

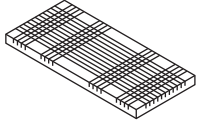

(83-70481)
 83-70469/83-70470/83-70471/
 83-70461/83-70462/83-70463/
 83-70472/83-70473/83-70474/
 83-70475/83-70476/83-70477/
 83-70478/83-70479/83-70480

12 x (180)/190/200 x 90/120/140 cm



(83-10307)
83-10299/83-10300

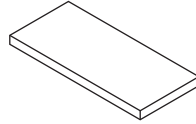

83-10303/83-10304
83-10312/83-10313/83-10387

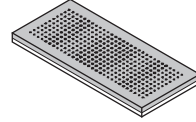

83-10301/83-10302



83-10435/83-10415
83-10436/83-10437/83-10438

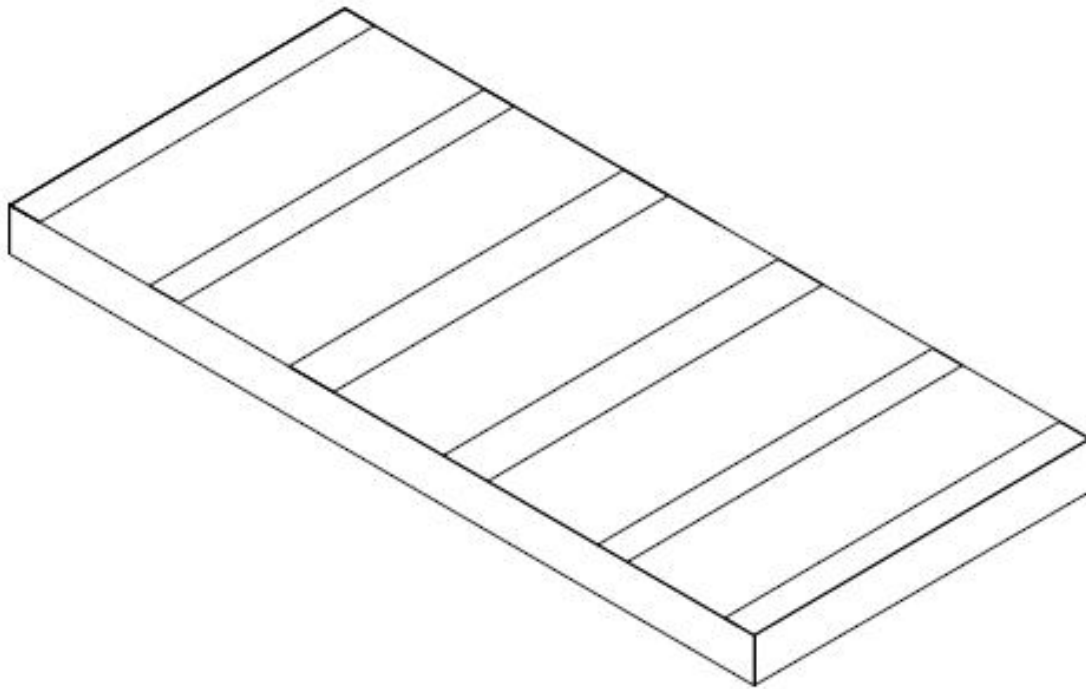

Monterings- og brugsvejledning
 Assembly instructions and direction for use
 Montageanleitung und Gebrauchsanweisung
 Notice de montage et mode d'emploi
 Montageinstructie en onderhouds voorschrift
 Instrucciones de montaje y uso
 Istruzioni di montaggio e uso
 Kokoamis- ja käyttöohjeet
 Οδηγίες συναρμολόγησης και χρήσης

Instrukcje montażu i wskazówki dotyczące użytkowania
 Instruções de montagem e de utilização
 Instrucțiuni de asamblare și recomandări de utilizare.
 Инструкции по сборке и руководство использования
 安装及使用说明
 組立ておよび使用説明
 รายละเอียดเกี่ยวกับวิธีการใช้
 และการติดตั้ง
 설치 및 취급설명

For indoor domestic use

83-10307/
83-10299/83-10300

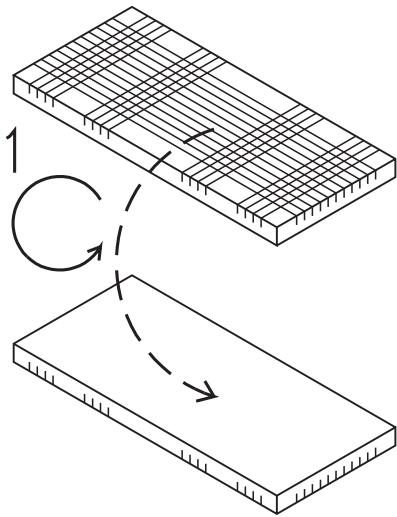

83-10301/83-10302

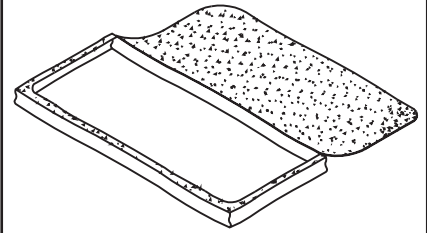
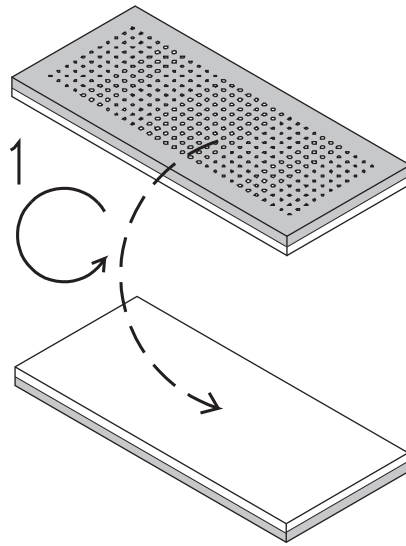

83-10303/83-10304/
83-10312/83-10313/
83-10387

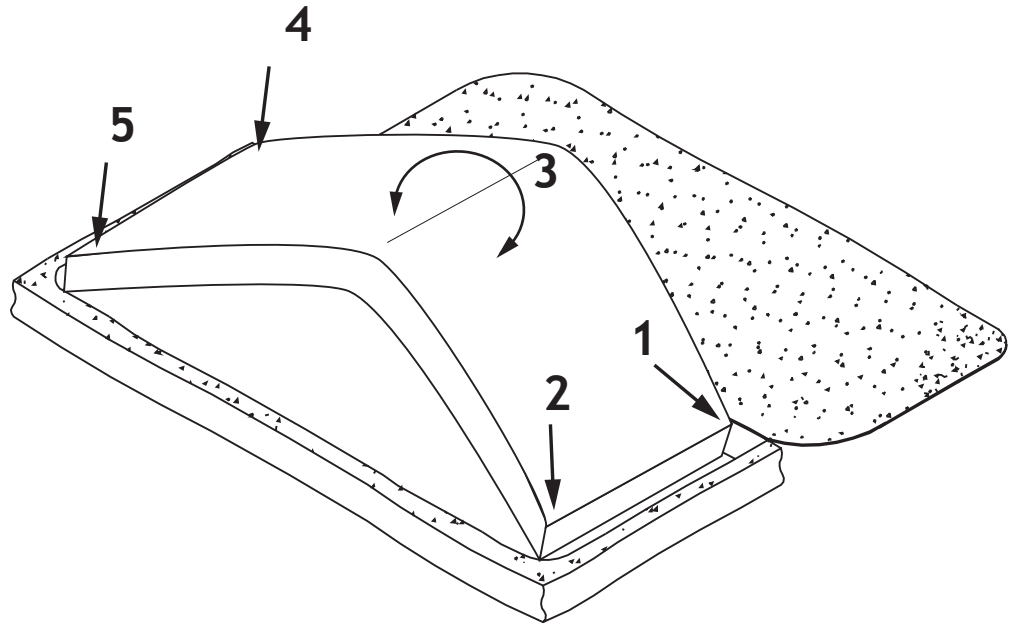
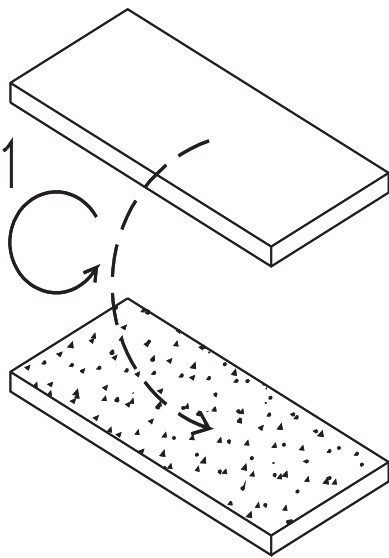

83-103405/83-10415/
83-10436/83-10437/
83-10438

A < 40kg

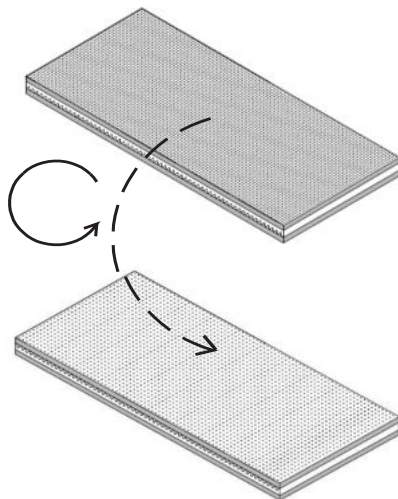

83-103405/83-10415/
83-10436/83-10437/
83-10438

B > 40kg

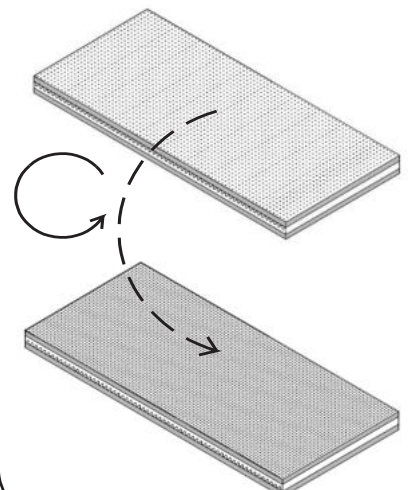

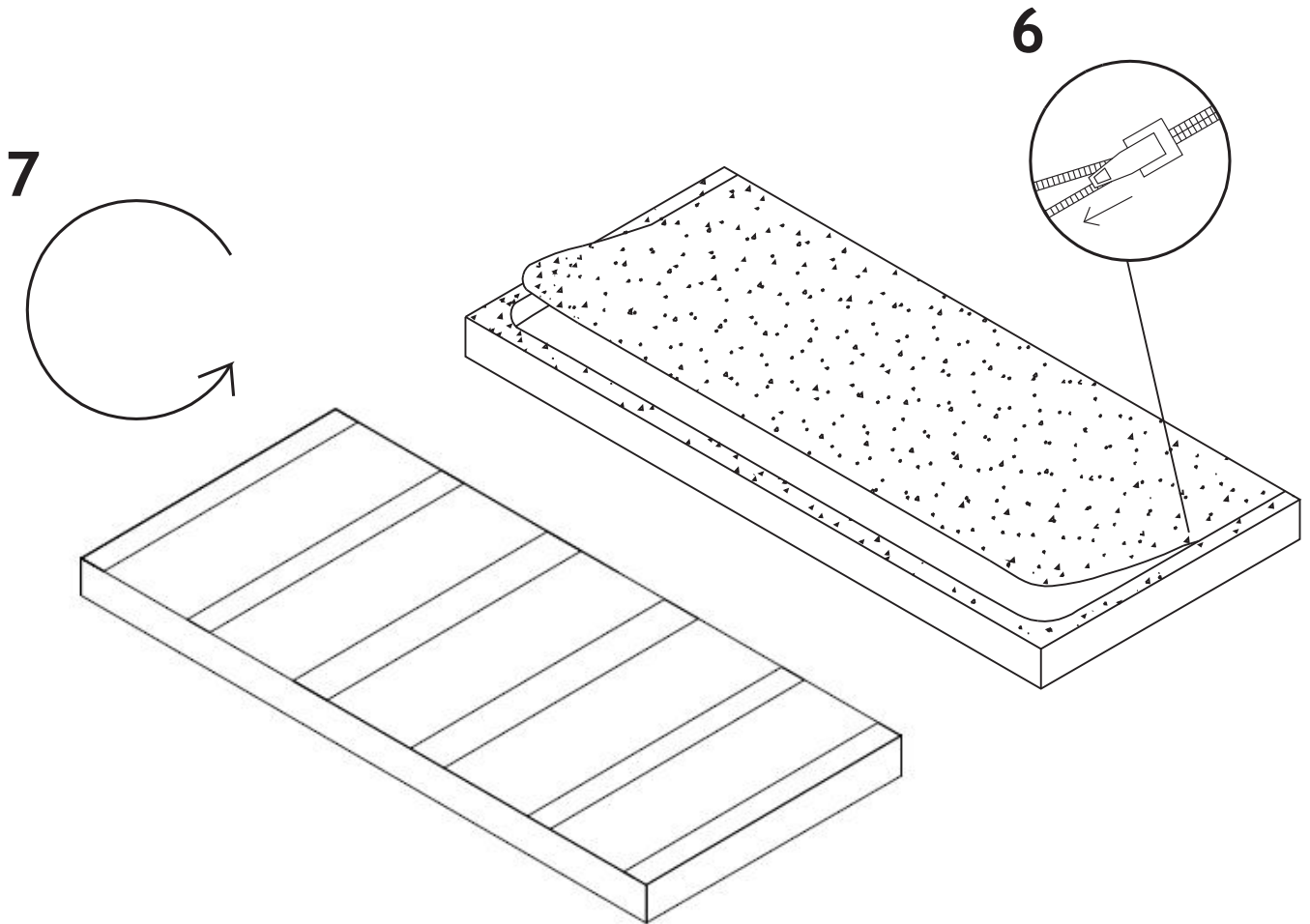

- DK: Madrassen skal være pakket ud i 24 timer, inden betrækket påføres, for at opnå den maksium komfort.
- GB: The mattress must be unwrapped for 24 hours, to ventilate, before the sheet is put on. By doing this maximum comfort will be obtained from your mattress.
- D : Die Matratze muss 24 Stunden ausgepackt sein bevor der Bezug aufgezogen werden kann, damit maximaler Komfort erreicht wird.
- F : Déballer le matelas 24 heures avant l'utilisation et avant de mettre la housse pour obtenir le meilleur confort.
- E : Para lograr un confort óptimo el colchón tiene que estar desembalado durante 24 horas antes de poner la funda.
- NL : De matras moet uitgepakt 24 uur geventileerd worden voordat de tijd er omheen getrokken wordt. Alleen op deze wijze wordt het maximale comfort van uw matras bereikt.
- I : Si consiglia di lasciare il materasso senza imballaggio per 24 ore prima che venga messo il rivestimento, in modo di ottenere il massimo di comfort.

Manufacturer: FLEXA4Dreams Holding A/S, Denmark
Address: Hornsyld Industrivej 4, 8783 Hornsyld, Denmark
Tel: +45 7668 8055 Fax: +45 7668 8069
Email: flexa@flexa.dk
Website: www.flexaworld.dk